

METAL CIRCULAR SAWING MACHINE

CIRCULAR SAWING
THE FASTEST AND
MOST ACCURATE
CUT-OFF PROCESS

Model S225

- For Cutting Steel, Stainless Steel and Nonferrous Tubes and Profiles
- With HSS Sawblade Ø 225 x 32 mm (9")
- Head Meters Through 0°-45°-60°
- Strong Vise, Opens 102 mm (4")
- Low Consumption Oil Lubrication
- Cast Aluminium Guards
- Worm & Wheel Drive
- 1-ph. or 3-ph. Motor
- Cast Iron Base

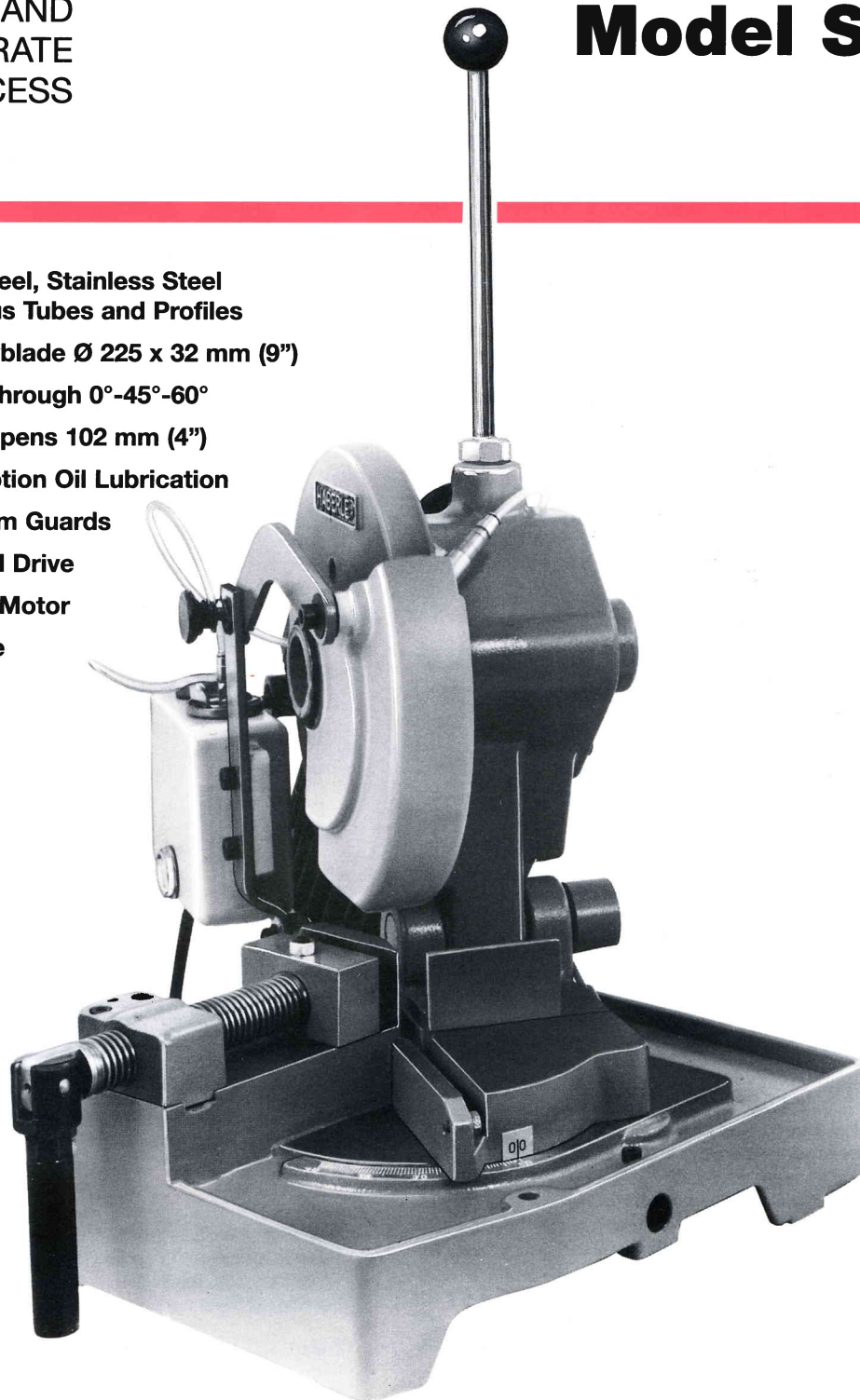

S 225
in 60° mitering position,
with standard vise

**THE UNBEATABLE COLD SAWS:
MADE IN GERMANY SINCE 1960**

HÄBERLE®

MODEL S 225: A POWERFUL SAW FOR SITES, INSTALLATION AND WORKSHOPS

Safety Sawblade Guard

Swing guided double guard of cast aluminum, covers the sawblade totally in rest position. Moving the saw head, the guard opens in the cutting area only, for best operator's safety. Quick release lift-up system to change the sawblade.

Drive Gears

Precision worm & wheel drive: Hardened and ground worm shaft. Strong main spindle runs in oil, free of maintenance. Special bronze wheel for long life. Available with standard or reduced speeds.

Available Motors & Electric

50 Hz Cycle: 1-phase 1-speed motor 230 V, 1.0 kW (1.3 HP), 3-phase 2-speed motor 400 V or 415 V, 0.8/1.2 kW (1.1/1.5 HP).
60 Hz Cycle: 1-phase 1-speed motor 110 V, 1.2 kW (1.5 HP), or 3-phase 2-speed motor 220 V or 460 V, 0.9/1.35 kW (1.2/1.6 HP).

Sawblade Speeds

50 Hz Cycle: 56 RPM or 56/112 RPM for steel & nonferrous metals. Reduced speeds: 42 RPM or 42/84 RPM, allows also stainless steel.
60 Hz Cycle: 66 RPM or 66/132 RPM for steel & non-ferrous metals. Reduced speeds: 50 RPM or 50/100 RPM, also for stainless steel.

Vise Systems

Standard with single mechanical vise. Strong buttress $\varnothing 27 \times 4$ mm (1.2"). Optional: double-grip vise with replaceable jaw plates, allows burr-free straight cuts and profiled jaws for special applications. Maximum clamping range with jaw plates in place: 80 x 60 mm (3.1 x 2.4").

Cutting Range mm (Inches)

with sawblade $\varnothing 225$ mm sawblade flange $\varnothing 70$ mm:

○	$\varnothing 70$ (2.7") 90°; 65 (2.5") 45°; 55 (2.2") 30° acute
□	60x60 (2.5") 90°-45° 50x50 (2") 30° acute
▭	80x60 (3"x2.5") 90°; 70x50 (2.7"x2") 45° 100x50 (4"x2") 90°
● ■	40 (2.5") mild steel and nonferrous metals only.

HSS Sawblades

$\varnothing 225 \times 2 \times 32$ mm (9"), with 2 drive holes $\varnothing 8$ mm, cycle $\varnothing 45$ mm. A sawblades flange of $\varnothing 70$ mm allows the maximum cutting depth.

Machine Table, Pivot Bearing

Mitering table allows acute mitering to the left within 60°. Engraved 1° graduation, with quick stop bolt at 45°, strong clamp bolt M12 (1/2"). In any position, the work-piece is supported on both sides close to the sawblade (see picture overleaf). Large double yoke pivot system with 100 mm (3.9") bearing length and cast iron base care for high stability.

Innovative Sawblade Lubrication

Patented mechanical low-consumption lubrication system, specially designed to use the machine on sites and installation, cares for permanent oil supply to the sawblade without any air or electric power. A brush besides the sawblade applies pure cutting oil out of an oil cell. When starting to work, this cell has to be filled up with oil out of the 500 ccm tank by the hand operated oil pump placed on the tank. The oil cell and the capillary hose to the tank care for permanent oil lubrication for hours. Only very little oil is used up, the tank volume will last for more than 100 hours of operation. Machine, chips, material and workbench remain dry and clean. English instruction label on the tank.

HÄBERLE® S 2000 Metal Cutting Oil

Biodegradable oil for metal cutting operations, free from mineral oils or any harmful substances, cares for a long tool life. Extremely high lubricating power leads to very poor warm up, water cooling is not necessary. S 2000 also can be used as screw-cutting oil on pipes and for other metal processing, for pure application, best for all metals.

S 225 ▶
shown with
standard
vise



S 225 ▶
with optional
double-grip vise



Dimensions & Weights

Table machine with handle: 650 x 300 x 720 mm, 48 kg (110 lb.)
 Table machine, packed: 680 x 340 x 770 mm, 58 kg (130 lb.)
 Fabricated steel stand: 600 x 400 x 800 mm, 20 kg (45 lb.)

Standard Equipment

Instruction manual in English with parts list, operating wrenches, single vise, mechanical oil lubrication system, 1 bottle with 1000 ccm cutting oil HÄBERLE S 2000.

Optional Equipment

Double-grip vise with jaw plates set, sawblade, cutting oil, fabricated steel stand, small length stop 1 meter (40"), graduated length stops.

Details are subject to change. HÄBERLE supplies cold saws up to sawblade $\varnothing 450$ mm, tube deburring machines, roller tables and equipment.

HÄBERLE®

...Simply the Best

FRANZ HÄBERLE
MASCHINENFABRIK
 D-76571 Gaggenau
 Tel.: (+49)-7225 3981
 Fax: (+49)-7225 71100

Sole Agents for USA:

Ken Bergman & Assoc.
 Oak Lawn / Chicago IL 60453
 Call toll free: 1-800-956-1313

Australian Sole Agents:

Superior Saws Pty., Ltd.
 Smithfield/Sydney, NSW 2164
 Tel: 2-891-1700, Fax: 2-681-1542